

See discussions, stats, and author profiles for this publication at: <https://www.researchgate.net/publication/251887593>

Design and implementation of radio frequency glow discharge system

Article · May 2009

DOI: 10.1109/BIYOMUT.2009.5130265

CITATIONS

0

READS

126

4 authors, including:



Erhan Ocak

Baskent University

1 PUBLICATION 0 CITATIONS

[SEE PROFILE](#)



İsmail Cengiz Koçum

Baskent University

42 PUBLICATIONS 342 CITATIONS

[SEE PROFILE](#)



Dilek Cokeliler

Baskent University

40 PUBLICATIONS 302 CITATIONS

[SEE PROFILE](#)

Some of the authors of this publication are also working on these related projects:



Data analysis for detection and estimation based on very observed samples in non stationary noise [View project](#)

Design and construction of uniform glow discharge plasma system operating under atmospheric condition

C. Koçum and H. Ayhan

Biomedical Engineering Department, Başkent University, Ankara 06530, Turkey

Chemistry Department, Biochemistry Division, Muğla University, Faculty of Science, Köteklî, 48170 Muğla

(Received 27 October 2006; accepted 7 May 2007; published online 4 June 2007)

The design of a uniform glow discharge plasma system operating without vacuum is presented. A full-bridge switching circuit was used to switch the transformers. The primary windings of transformers were connected in parallel, but in opposite phase to double the output voltage. Theoretically, 20 000 V_{pp} was obtained. Rectangle copper electrodes were used, and placed parallel to each other. To prevent the spark production that is, to obtain uniformity, two 2 mm Teflon sheets were glued to the electrodes. However, it was observed that the operating frequency also affected the uniformity. For the system presented here, the frequency at which more uniformity was obtained was found to be 14 kHz. © 2007 American Institute of Physics. [DOI: 10.1063/1.2745230]

I. INTRODUCTION

Nowadays, plasma technology is one of the very common methods which are used for surface modification, coating, and etching in industries and scientific laboratories. Modification or treatment of a surface by applying glow plasma is also a known technique in industries, such as photofilm production industry, semiconductor industry, textile industry, for sterilization in some industries and biosensor applications, and also for biomedical materials and devices in order to improve certain surface and material properties.^{1–10}

Mainly, there are three different methods used in plasma technology. The first method is the glow discharge; it is produced at a reduced pressure and assures the highest possible uniformity and flexibility of any plasma treatment in vacuum. It is formed by applying a direct current, microwave, low frequency (50 Hz), or radio frequency (40 kHz, 13.56 MHz) voltage over a pair or a series of electrodes. The second method is the corona discharge; it is formed at atmospheric pressure by applying a low frequency or pulsed high voltage over an electrode pair as applied in the various configurations. The corona consists of small lightning-type discharges, their inhomogeneity and the high local energy levels make the classical corona treatment of surfaces problematic in many cases. The third method is the dielectric-barrier discharge; it is formed by applying a pulsed voltage over an electrode pair at least one of which is covered by a dielectric material.

Glow discharge plasma treatment has considerable advantages if it is generated at atmospheric pressure^{11–13}, by using either rf or dielectric-barrier discharge. However both systems have some problems in atmospheric conditions. Some of the main problems are difficulties in obtaining desired uniformity and spark formation. rf plasma which has the frequency of 13.56 MHz can also be used at atmospheric pressure;¹⁴ on the other hand producing rf plasma generators at atmospheric pressure with necessary power especially of

hundred watts or more is not easy. The reason is that, completely special electronic components are needed for these power scales. Reflected power is also another problem, because it does not only decrease the efficiency, but also causes the dramatic destruction of generator itself as well. To prevent the rf generator against reflected power, special protection circuits and impedance matching units are always required.

In this article, a complete and relatively easier uniform glow discharge system for laboratory and small scale industrial applications is presented. Here we give a design overcoming the uniformity problems related to operation at atmospheric pressure.

Our system was designed and constructed in our laboratories and has four main parts, which are dc power supplies, control circuit, full-bridge switching power section, and high voltage electrode section.

II. dc POWER SUPPLIES

In this part of the system, mainly two different power supplies are constructed. One is for control circuit, and the other is for the power section. The power supply for power section is an ordinary 200 W, 40–50 V_{dc} supply which has a transformer, bridge diode, and capacitor of 4700 μF. But the other supply for control circuit has a speciality; it has five independent coils on the same core. Each coil is 15 V_{ac} and has a capacity of 1 A. A bridge diode, 1000 μF of capacitor, and an integrated voltage regulator of 7812 were used for each coil. By this independency five different electrically isolated power supplies were obtained. The reason for this type of production is that obtaining, both commercially and technically, a high voltage high power *p* channel metal-oxide-semiconductor field-effect transistor (MOSFET) is impossible for now. Only *n* channel MOSFETs can be achieved for full-bridge high power switching system and this system needs isolated driving. Therefore, four of these

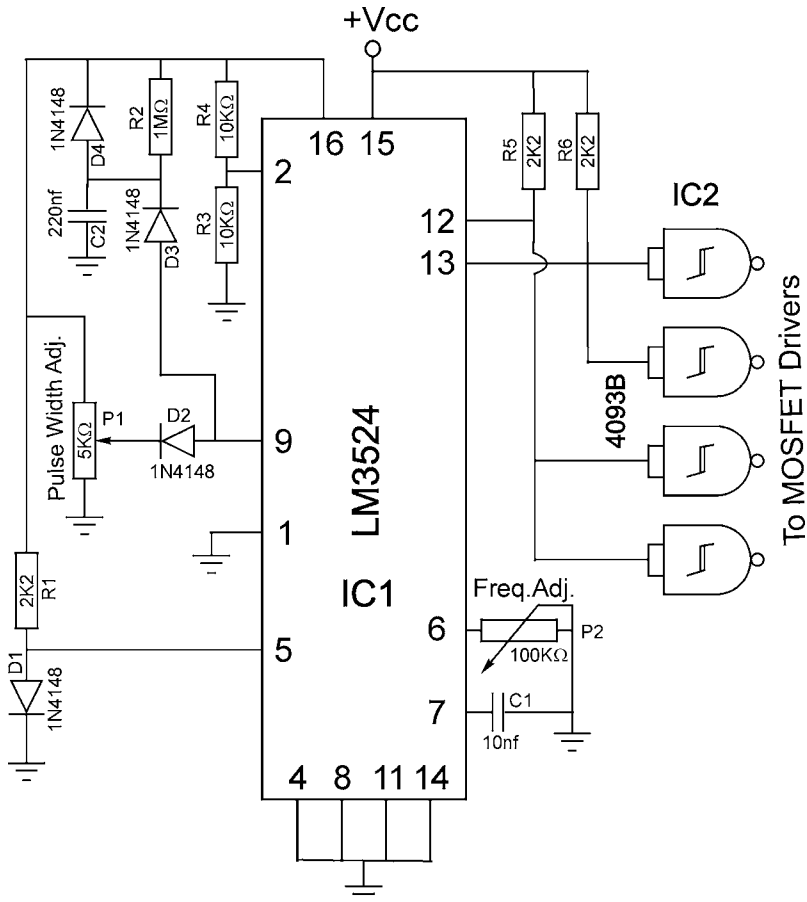

FIG. 1. Control circuit of plasma system.

power supplies were used for driving of optically isolated MOSFET drivers of each MOSFET. Remaining one of them was used to supply the control circuit.

III. CONTROL CIRCUIT

As it is known, pulse-width modulation is a well known technique which is used for power adjustment and voltage regulation in switching power circuits. Integrated circuit (IC) of LM3524,¹⁵ which is produced for switching supplies, was used as pulse-width modulator in the control circuit. Frequency of oscillator inside of LM3524 can be determined by adding a resistor and a capacitor externally. Here, by using 10 nF of capacitor and 100 kΩ of potentiometer, the frequency of the system can be adjusted in the range of 600 Hz–25 kHz. But we observed that efficiency of high voltage transformers decreased dramatically above 17 kHz.

Error amplifier and current sense amplifier of LM3524 are connected to constant voltages for maximum and constant pulse width of control signal. But the control of pulse width of control circuit was obtained by using frequency compensation pins of LM3524. By this way pulse-width modulation was not used for voltage regulation, but it was used to adjust manually the power for appropriate operating conditions. Pulse-width ratio is limited by manufacturer to the value of 44% at low frequencies for short circuit protection of MOSFETs during the switching. The control circuit schematic mentioned above and its part list are given in Fig. 1 and Table I.

An illustration representing pulse-width variation is given in Fig. 2. As shown in Fig. 2, with this technique even though the pulse-width changes, the frequency stays at its own value. The only way to change frequency is to adjust the potentiometer manually.

TABLE I. Part list of control circuit.

Resistors:	Semiconductors:
R1, R5, R6=2 kΩ	D1, D2, D3=1N4148
R2=1 MΩ	IC1=LM3524
R3, R4=10 kΩ	IC2=4093B
P1=ten turn pot.=5 kΩ	
P2=ten turn pot.=100 kΩ	
Capacitors:	
C1=10 nF	
C2=220 nF	

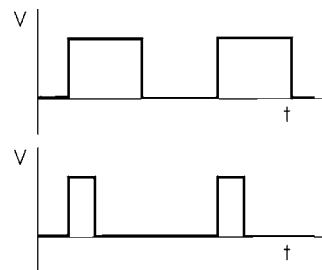

FIG. 2. Example of driving signals which have the same frequency but different pulse widths.

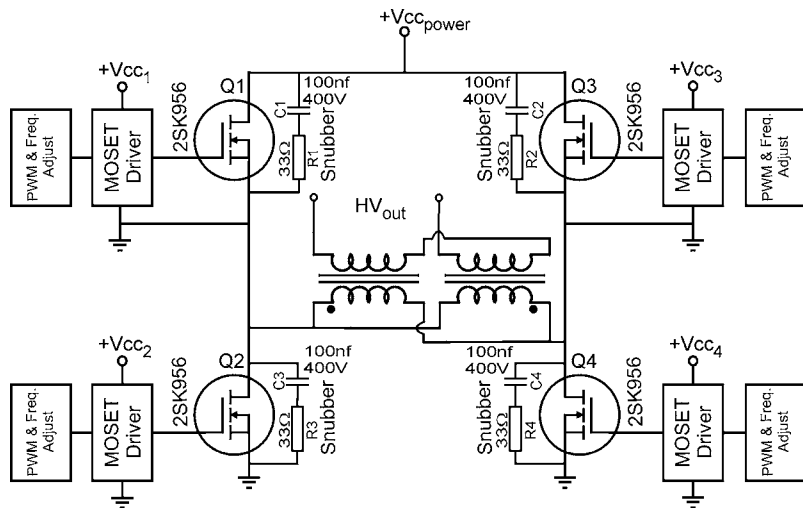

FIG. 3. Full-bridge switching circuit of power section.

The produced control signal is transferred to two outputs of LM3524 by the aid of a logic circuit in the IC. Two outputs have 180° phase difference between them. This control signal was led to a buffered NAND gate which is 4093B. This IC is used for signal enhancement, and as a buffer between LM3524 and MOSFET drivers. This NAND gate has a complementary output which is very important to drive capacitive loads, light emitting diodes (LEDs), piezoelectrics, etc., as rising and falling times of signal are one of the most important parameters for the efficient switching speed.

IV. POWER SECTION

In this part of the study, one of the switching technique which is known as full-bridge system was used.

Working principle of power section and its part list are given in Fig. 3 and in Table II. Integrated circuit of TLP250 was used as MOSFET drivers to isolate the control circuit from power section electrically. TLP250s have half-bridge output section. This is important, because all of the power MOSFETs' gates have relatively great capacitance for switching applications. Therefore, this gate capacitance should be charged and discharged fast by active components. The output section of TLP250 has this capability of half-bridge property. This property provides faster charging and discharging of the MOSFETs' gates which result in a certain decrease of the current rising-falling time. This is most desirable, by this way, energy dissipation is reduced, and thus

the overheating of MOSFETs has been solved. In our system rising and falling times were measured and it was found that their values were faster than 100 ns. This value is enough for around 10 kHz operating frequency but our device has 6 A current requirement at maximum power, and this requirement will cause a resistive heat problem. To overcome this problem, we used two MOSFETs in parallel for each switching node, by this method resistive unwanted heat reduced by one-half. At the same time the transistors were mounted on 2 mm thick aluminum of 150 cm^2 , and were isolated electrically.

The power section was supplied with $40\text{--}50 \text{ V}_{\text{dc}}$, but 800 V, 9 A MOSFET of 2SK956 was used because of unwanted spikes produced by high voltage transformers. However, it was observed that this was not enough without snubber. Therefore, an RC snubber with 33Ω and 100 nF connected parallel between drain and source leads of each transistor.

As shown in Fig. 3, when Q1-4 are at the saturation point, Q2-3 are in cutoff. On the contrary in the next cycle, when Q2-3 are at the saturation point, Q1-4 are in cutoff. By this way the current flows continuously in opposite direction at each cycle.

V. HIGH VOLTAGE AND ELECTRODE SECTION

Electrodes were made from two copper sheets which have dimensions of $50 \times 60 \times 0.3 \text{ mm}^3$, and they were placed and glued on to flexiglasses in parallel to each other. For each electrode, $80 \times 90 \times 2 \text{ mm}^3$ Teflon sheets were used as dielectric material. Copper electrodes were sandwiched between flexiglass and the Teflon sheets. Electrode gap can be adjusted from 4 to 12 mm by a screw mechanism.

For the transmission of high voltage to electrodes, silicon cables were used and mounted far from each other to prevent spark and discharges between them.

In this section the transformers which have around 1:100 turn ratios were used. The selected core material is of audio-or car-ignition-type iron transformer core instead of ferrite core. In some studies it has been mentioned that the high frequency oscillations create a major risk for plasma stability because of the relatively low value of self-

TABLE II. Part list of power section.

Resistors:

R1, R2, R3, R4=33 Ω , 5 W

Capacitors:

C1, C2, C3, C4=100 nF, 400 V

Semiconductors:

MOSFET drivers=TLP250

MOSFET=2SK956

Transformers:

(1) $2 \times 100 \text{ W}$ HV transformer with iron core which has oil or polymer HV isolation.

(2) 110–220 V to $5 \times 15 \text{ V}$, 1 A transformer

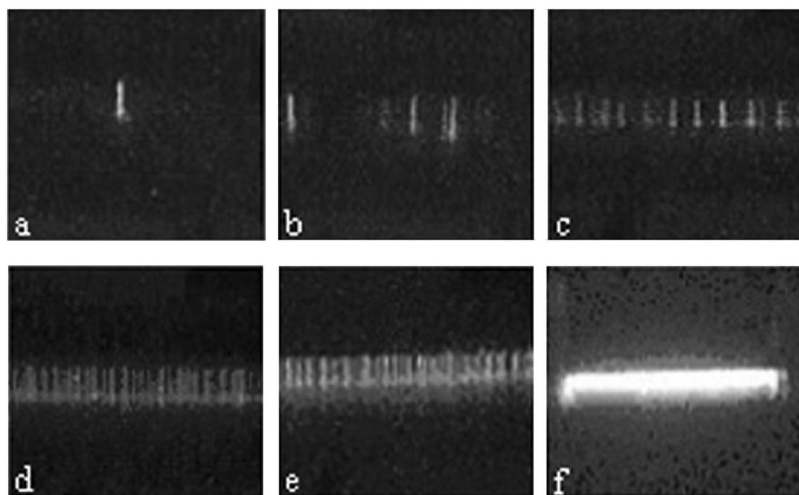

FIG. 4. [(a)–(f)] Acquisition of homogeneous discharge from spark stage to glow stage in progression at matching conditions (voltage, duty cycle, operating frequency, and gap of the electrode).

inductance of the plasma system.^{3,16} In these works, the transformers of power supplies which are used for energizing the electrodes have probably ferrite core. So that system's high frequency response is better, but this may cause as it is admitted, high frequency oscillations and plasma breakdown. In the above mentioned studies, suggested solution to this problem is to use a serial choke coil which has high reactance value.^{3,16} In our study, transformers' primary windings were connected in parallel to each other and their secondary windings were connected serially. By this way, a reactance of 2.3 mH was obtained in primary and of 32 H in secondary. So this transformer stage has high reactance but poor high frequency response which is apparently desirable in respect of the prevention of high frequency oscillations and plasma breakdown.

The proposed system does not have fixed duty cycle. Our duty cycle is adjustable and can be used both to adjust the plasma power and to prevent the spark formation. By this way some unwanted spark formations can be minimized at the operating conditions. This system was tested up to 200 W with 44% duty cycle, without any spark formation.

In this research, manual frequency adjustment is an important system property: it can be used to get the system in resonance with its own capacitance (self-capacitance of transformers and electrodes) and its own inductance. By this way energy transfer efficiency would be better without using bulky high voltage, high power capacitors, and coils for matching network suggested.^{3,16}

With this 1:100 turn ratio and 50 V_{dc} supply it is possible to reach up to 10 000 V_{pp}, but it was observed that this value is critical and may become insufficient for 1 cm electrode gap used conveniently. So, two transformers were connected in parallel to the switching circuit as shown in Fig. 3. By this way 20 000 V_{pp} was reached between electrodes theoretically. It is also possible to reach more than this value by getting the transformers to self-resonance by adjusting frequency. In this system this frequency was obtained around 14 kHz with the parallel electrodes. According to distance between electrodes, this value is changed approximately ± 1 kHz around the center frequency of 14 kHz. These resonating conditions also affect the homogeneity of the discharge with the electrode gap as given in Fig. 4. As shown in

Fig. 4(a) and 4(c), discharge occurs as spark when the electrode gap and operating frequency are not matched. This spark heats the single point of dielectric materials, electrodes, and also the sample, and leads to overheating which in turn would cause dramatically destruction of them. But when the system parameters (transformer type, voltage, duty cycle, operating frequency, and gap of the electrode) are designed and adjusted in favorable matching conditions, result in homogeneous glow discharge can be reached in progressive stages, as shown in Fig. 4(d) and 4(f).

The images in Fig. 4 were taken in atmospheric conditions at room temperature with and without gas flows. In literature and some patents, it was pointed that transition to spark or arc can be prevented by limiting the current density and the plasma duration, by using high gas flows.³ Additionally our study shows the importance of the parameters used, i.e., transformer type, voltage, duty cycle, operating frequency, and gap of the electrodes.

In conclusion our study presents a plasma system which has novelties: a power supply with adjustable frequency and duty cycle, an implementation of iron core transformer. Since we do not have any problem with high frequency operation, the designed system can attain deliberately the resonant frequency for maximum power transfer and uniformity. Consequently we obtain much more efficient and uniform glow, as shown in Fig. 4(f). We suggest that this plasma system can be acceptable for various applications in small scale industrial and laboratory works.

¹S. Pane, R. Tedesco, and R. Greger, *J. Industrial Textiles* **31**, 135–145 (2001).

²G. Allan, A. Fotheringham, and P. Weedall, *AUTEX Research Journal*, **2** (2) (2002).

³H. W. De Vries, F. Mori, E. Aldea, and M. C. M. Van de Sanden, U.S. Patent Appl. 2004/0011764 A1 (January 22, 2004).

⁴E. Özdoğan, R. Saber, H. Ayhan, and N. Seventekin, *J. Soc. Dyers Colour.* **118**, 100 (2002).

⁵T. Öktem, H. Ayhan, N. Seventekin, and E. Pişkin, *Indian Journal of Fiber & Textile Research* **27**, 161 (2002).

⁶F. Ayhan, H. Ayhan, and E. Pişkin, *J. of Bioactive and Compatible Polymers* **13**, 65 (1998).

⁷T. C. Montie, K. Kelly-Wintenberg, and J. R. Roth, *IEEE Trans. Plasma Sci.*, **28**, 1 (2000).

- ⁸S. Mutlu, R. Saber, İ. C. Koçum, and E. Pişkin, *Anal. Lett.*, **32**, 317 (1997).
- ⁹N. Özden, H. Ayhan, S. Erkut, G. Can, and E. Pişkin, *Dent. Mater.*, **13**, 174 (1997).
- ¹⁰A. Yousefi Rad, H. Ayhan, Ü. Kısa, and E. Pişkin, *J. Biomater. Sci., Polym. Ed.* **9**, 915 (1998).
- ¹¹H. de Vries, F. Mori, E. Aldea, and M. C. M van de Sanden, U.S. Patent Appl. 2004/0007985 A1 (January 15, 2004).
- ¹²H. de Vries, F. Mori, E. Aldea, and M. C. M. van de Sanden, U.S. Patent Appl. 2006/0022606 A1 (February 2, 2004).
- ¹³E. Aldea, P. Peeters, H. de Vries, and M. C. M. van de Sanden, *Surf. Coat. Technol.* **200**, 46–50 (2005).
- ¹⁴J. Park, I. Henins, H. W. Herrman, and G. S. Selwyn, *J. Appl. Phys.* **89**, 1 (2001).
- ¹⁵*General Purpose Linear Devices Databook*, (National Semiconductor, Santa Clara, 1989), pp. 2–24.
- ¹⁶H. de Vries, F. Mori, E. Aldea, and M. C. M van de Sanden, U.S. Patent 2006/0081566 (April 20, 2006).