

# Effect of shoulders on bending moment capacity of round mortise and tenon joints

Carl Eckelman\*

Yusuf Erdil\*

Eva Haviarova\*

---

## Abstract

Tests were conducted to determine the effect of close-fitting shoulders on the bending moment capacity of round mortise and tenon joints. Results indicate that close-fitting shoulders can substantially increase the strength of the joints and that useful estimates of the contribution of shoulders to the bending moment capacity of round mortise and tenon joints may be obtained by means of the following expression:

$$F_s = 0.934 \times \frac{2w}{D^{1.66}} \times F_{ns}$$

where  $F_s$  and  $F_{ns}$  = bending moment capacities of joints with and without shoulders, respectively (in-lb);  $w$  = distance from the longitudinal axis of the tenon to the lower edge of the stretcher (in); and  $D$  = diameter of the tenon (in). Simple working relationships between shifts in neutral axis, which result from the use of shoulders, and bending moment capacity were not found. Close fits can be obtained through the use of somewhat complex relationships, but these were not judged useful for practical design purposes.

---

Performance tests of furniture constructed with round mortise and tenon joints indicate that when the shoulders on the tenons fit closely against the walls of the members in which the tenons are inserted, the shoulders considerably increase the bending moment capacities of the joints. Knowledge about this behavior is important not only in estimating the expected performance of existing furniture but also in designing durable furniture to meet severe end-use requirements.

Overall, these performance tests tend to indicate that for square members, the increased bending moment capacity of round mortise and tenon joints with shoulders is functionally related to the ratio of  $W/D$  where  $D$  is the diameter of the tenon and  $W$  is the width of the member in the plane of the bending moment (hereafter referred to as a “stretcher”). Presumably, these increases in strength are related to the shifting of the neutral axis of the tenon owing to loading of the shoulder along with a transition in the primary mode of loading of the tenon from bending to withdrawal.

Because of the potential contribution of shoulders to bending moment capacity, an exploratory study was undertaken in order to investigate the characteristics of the “shoulder” effect and, if possible, to develop a practical expression for estimating the bending moment capacity of round mortise and tenon joints with shoulders. Results of the study are given below.

## Description of study

In general, the study consisted of comparing the bending moment capacities of round mortise and tenon joints constructed with shoulders with the bending moment capacities of comparable joints without shoulders (Fig. 1). Overall, the study was divided into three parts, which were carried out consecutively.

The first part of the study was conducted to investigate whether a regular relationship between shoulder width and bending moment capacity could be shown to exist. Hence, specimens for this limited study were constructed with only one tenon diameter but with several square stretcher widths. To reduce variability and allow “one-on-one” comparisons of the bending moment capacities of joints with and without

---

The authors are, respectively, Professor, Dept. of Forestry and Natural Resources, Purdue Univ., West Lafayette, IN (eckelmac@purdue.edu); Associate Professor of Wood Science and Furniture Design, Mugla Univ., Kotekli, Mugla, Turkey (yziya@mu.edu.tr); and Assistant Professor, Dept. of Forestry and Natural Resources, Purdue Univ. (ehaviar@purdue.edu). This paper was received for publication in August 2004. Article No. 9920.

\*Forest Products Society Member.

©Forest Products Society 2006.

Forest Prod. J. 56(1):82-86.

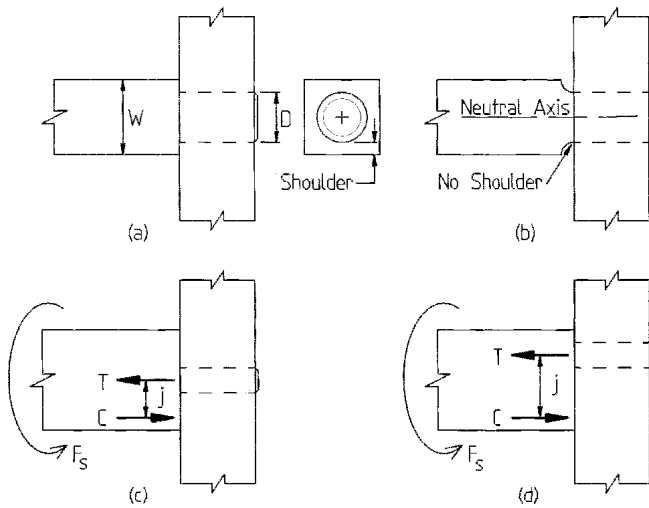

Figure 1. — Illustration of tenons with (a) and without (b) shoulders, and positions of internal moment arm (c) and (d).

shoulders, a tenon with a shoulder was cut on one end of each stretcher and a tenon without a shoulder on the other end (Fig. 2a). The tenon on one end of the stretcher was then used to construct a joint with a shoulder and the tenon on the other end a joint without a shoulder (Fig. 2b) to form a pair of “matched” joints.

Based on a positive result in the first part of the study, the second part was conducted to find a general relationship between tenon diameter, shoulder width, and bending moment capacity. Hence, both stretcher cross sections and tenon diameters were varied in constructing sets of “matched” joints.

The third part of the study was conducted to determine whether the expressions developed in the first two parts of the study could satisfactorily estimate the bending moment capacities of joints used in practical furniture constructions. To examine these relationships, stretcher to post joints (with shoulders) were cut from surplus chairs remaining from other studies and tested to determine their bending moment capacity. Estimates of the bending moment capacities of the joints were then compared to the test results.

### Description of specimens

In the first part of the study, 2-inch-long by 0.720-inch-diameter tenons were cut on both ends of yellow-poplar stretchers that measured 0.75, 0.875, 1.0, 1.125, and 1.25 inches square. Corresponding mortises were bored in yellow-poplar members (hereafter referred to as posts) that measured 1-1/2 inches square. Tenons with shoulders were fully inserted into the mortises so that the shoulders of the tenons fit snugly against the walls of the posts in which the tenons were embedded (Fig. 2). Tenons on the opposite ends of the stretchers were inserted into identical posts to a depth of 1-1/2 inches so that 1/2 inch separated the shoulders of the tenons from the walls of the posts. All of the tenons fit snugly in the mortises. Walls of the mortises were thoroughly coated with a 40 percent solids content aliphatic resin adhesive. Five specimens with shoulders and five specimens without shoulders were prepared for each stretcher size; thus, 25 joints were constructed with shoulders and 25 joints without. Average moisture content (MC) of the specimens was 9.8 percent.

In the second part of the study, 0.5-, 0.625-, 0.75-, 0.875-, and 1-inch diameter tenons were cut on the ends of 1-, 1.25-,

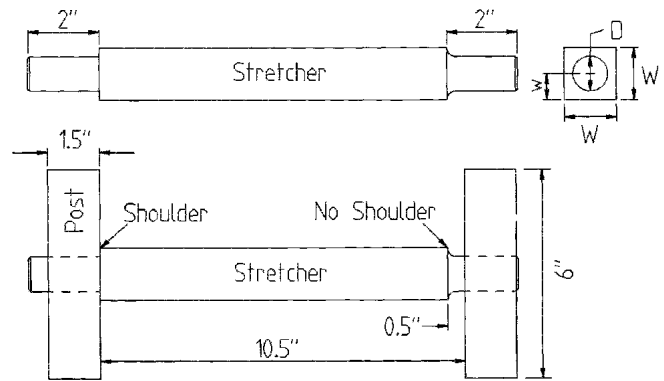

Figure 2. — Construction of matched joints with and without shoulders.

1.5-, 1.75-, and 2-inch square stretchers, as in the first part of the study (Fig. 2). Five joints were constructed for each combination for a total of 125 shoulder and 125 non-shoulder joints. Posts were constructed of 1-1/2 by 1-1/2-inch yellow-poplar material. All joints were glued as above. MC averaged 10.5 percent.

Each of the stretcher to post joints used in the third part of the study consisted of a stretcher and corresponding section of a front or back post cut from surplus chairs that had been used in other studies. Tenon diameters averaged 0.715 inch. Stretcher width ranged from 0.83 inch to 0.94 inch with an average of 0.899 inch and a standard deviation (SD) of 0.03 inch. Forty specimens had yellow-poplar (*Liriodendron tulipifera*) stretchers and 20 had red oak (*Quercus rubra*) stretchers; posts were constructed of loblolly pine (*Pinus taeda*). MC at time of test averaged 6.8 percent.

### Method of test

Specimens were mounted for testing in a universal testing machine as shown in Figure 3. A moment arm of 8 inches was used in all tests. Fall-off of peak machine load was used as the indicator of joint failure. Ultimate bending moment capacity was adjusted to account for the added moment resulting from weight of the stretcher and unsupported post. MC specimens were cut from the stretchers and weighed immediately after each test.

### Results and discussion

Linear representations of the results from the first part of the study are presented in Figure 4. In this graph, the middle curve represents the bending moment capacities of the joints with shoulders, the lower curve the capacities of joints without shoulders, and the upper curve the values of the lower curve multiplied by  $W/0.72$  where  $W$  refers to the width of the stretcher and 0.72 is the diameter of the tenon. The near parallel paths of the upper and middle curves indicated that simple useful relationships might exist, and that these could be used to estimate the contribution of a given shoulder to the bending capacity of a joint.

Results of the second part of the study are given in Table 1. A regression expression of the form  $F_{NS} = a \times D^b$  (where  $F_{NS}$  = bending moment capacity of joints without shoulders [in-lb];  $D$  = diameter of the tenon [in]), was fitted to the results for the tenons without shoulders in order to obtain a functional relationship between bending moment capacity and tenon diameter. The regression expression,  $F_{NS} = 1197 \times D^{2.80}$ , was

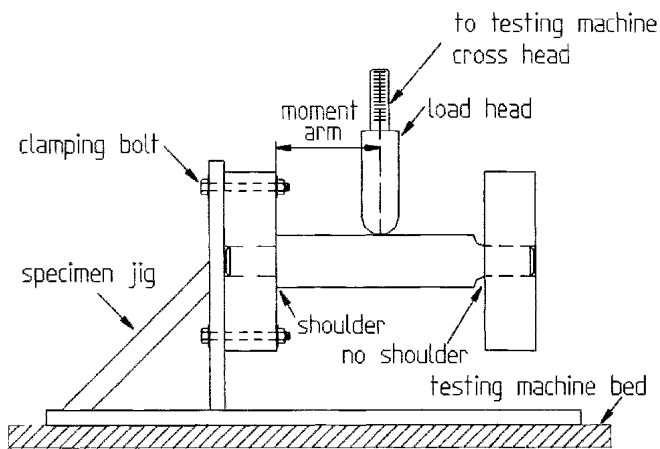

Figure 3. — Test set up used to evaluate bending moment capacity of joints.

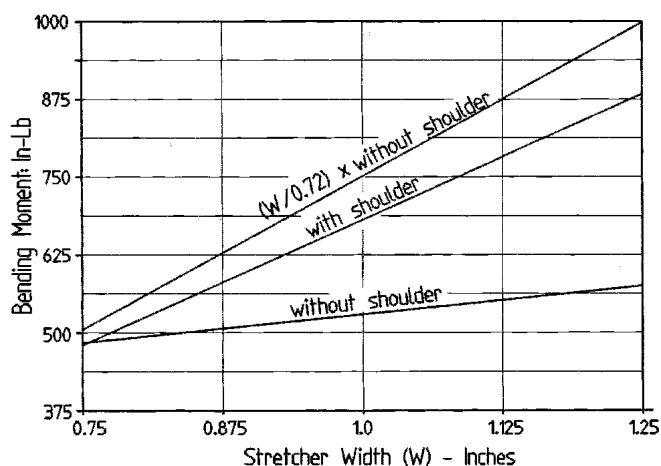

Figure 4. — Linear representations of capacities of joints with 0.72-inch tenons, both with and without shoulders; and values of  $(W/0.72) \times$  (without shoulder).

obtained with an  $r^2$  value of 98.8 percent. Values estimated by this expression are shown as the bottom solid line in **Figure 5**.

Regression expressions of the form:

$$F_S = a \times \left( \frac{2w}{D^b} \right) \times F_{NS}$$

were fitted to the individual data sets for tenons with shoulders for each stretcher width to allow for visual interpretation of the data. In this expression,  $w$  = distance from the longitudinal axis of the tenon to the lower edge of the stretcher (as shown in **Figure 2**,  $w = W/2$ );  $F_S$  = bending moment capacity of the joints with shoulders; and  $a$  and  $b$  = regression coefficients. Regression coefficients for these curves are given in **Table 2**, and plots of the values estimated by the expressions are shown in **Figure 5**. The regular increase in bending moment capacity of the tenons with shoulders can be seen clearly in this figure, both with respect to tenon diameter and stretcher width. This expression also was fitted to the combined test data for all stretcher widths. The expression:

$$F_S = 0.934 \times \frac{2w}{D^{1.66}} \times F_{NS} \quad [1]$$

resulted, with  $r^2$  equal to 97.44 percent. Plots of the values estimated with this expression are shown superimposed on the previous curves in **Figure 5**.

Finally, the above expression was fitted to the test results for the 1-inch stretcher widths along with the regression coefficient,  $b$ , set equal to 1. The simplified expression:

$$F_S = 1.08 \times (2w/D) \times F_{NS} \quad [2]$$

was obtained, with  $r^2$  equal to 99.95 percent. Values estimated by this expression also are shown plotted in **Figure 5**. As can be seen, these values essentially coincide with those estimated by Equation [1] for 1-inch stretchers. This specific expression was developed because it is particularly useful in treating the smaller size members commonly used as chair stretchers. It also clearly demonstrates the value of shoulders on tenons in chair stretchers. A 1-inch stretcher with shoulders, for example, with a 0.72-inch-diameter tenon, would have  $1.08 \times 1.0/0.72$ , or, 150 percent of the capacity of a similar joint without shoulders.

Average bending moment capacity of the yellow-poplar joints cut from chair frames was 713 in-lb with an SD of 109 in-lb; comparable values for the red oak joints were 906 in-lb and 65 in-lb, respectively. On average, Equation [2] over-predicted the bending capacity of the yellow-poplar joints by 1 percent and the red oak joints by 5 percent. Average for the pooled data was 1.02 percent.

#### Tenon withdrawal $\times$ internal moment arm

As illustrated in **Figures 1c** and **1d**, it appears reasonable to assume that as the width of the shoulder increases, the bending moment capacity,  $F_S$ , of the joint increasingly becomes a function of the withdrawal resistance of the tenon,  $T$ , multiplied by an internal moment arm,  $j$ , i.e.:

$$F_S = T \times j$$

where  $T$  = withdrawal resistance of the tenon loaded in tension (lb);  $j$  = internal moment arm measured between the longitudinal axis of the tenon and the internal resultant compressive force,  $C$  (in). An expression of this form has been shown to reliably estimate the in-plane bending moment capacity of conventional dowel joints (Eckelman 1971), but its applicability to tenons with shoulders has not been investigated. The withdrawal resistances of the tenons could not be determined by test without destroying the joints. Thus, withdrawal capacities were estimated by means of an expression (Eckelman 1969) developed to estimate the withdrawal capacities of dowels:

$$T = 0.834DL^{0.89} (0.95S_1 + S_2) \times A$$

where  $T$  = withdrawal capacity (lb);  $L$  = depth of embedment of the tenon in the mortise (in);  $S_1$  = shear strength of the post in which the tenon is embedded (psi);  $S_2$  = shear strength of the tenon (psi);  $A$  = combined adhesive/dowel-hole clearance factor. Based on previous research, a value of 0.83 can be assumed for  $A$  when close-fitting joints are assembled with at least a 42 percent solids PVA adhesive. When an expression of the form:

$$F_S = a \times w \times T$$

was fitted to the test results for tenons with shoulders along with the corresponding estimated withdrawal capacities of the tenons, the following expression resulted:

Table 1. — Average bending moment capacities of joints with five tenon diameters by five member widths, with and without shoulders.

Tenon diameter (in)	Member cross section										
	1 in		1.25 in		1.5 in		1.75 in		2 in		All
	With shoulder	Without shoulder	With shoulder	Without shoulder	With shoulder	Without shoulder	With shoulder	Without shoulder	With shoulder	Without shoulder	Without shoulder
0.5	362	172	580	180	733	176	918	167	1,098	167	172
0.625	548	322	778	329	955	325	1,161	315	1,368	315	321
0.75	768	537	990	540	1,186	539	1,407	531	1,638	529	535
0.875	1,023	827	1,214	821	1,423	825	1,655	825	1,906	820	824
1	1,310	1,203	1,448	1,180	1,667	1,193	1,905	1,208	2,174	1,199	1,197

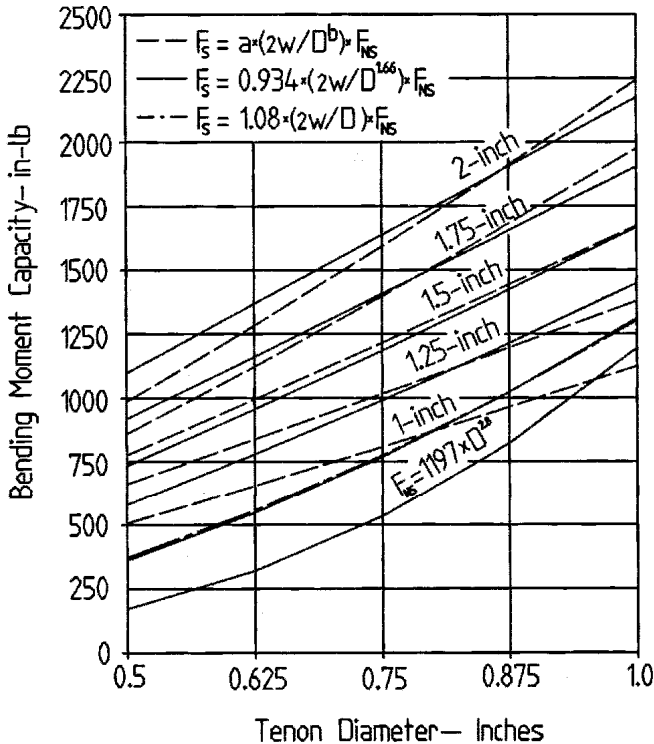

Figure 5. — Bending moment capacities of 0.5-, 0.625-, 0.75-, 0.875-, and 1-inch tenons with shoulders on 1-, 1.25-, 1.5-, 1.75-, and 2-inch stretchers. Coefficients for the top expression are given in Table 2.

$$F_s = 0.894 \times w \times T \quad [3]$$

with  $r^2$  equal to 89.0 percent.

Estimated bending moment capacities for the various tenon-diameter vs. stretcher-width combinations, based on Equation [3], along with the corresponding values for tenons with shoulders (previously shown in Fig. 5) are plotted in Figure 6. As can be seen, estimates of bending moment capacities for the larger member widths agree relatively closely with test values, whereas estimates for smaller widths differ considerably.

It should be noted that the vertical positions of the estimates shown in Figure 6 depend upon the calculated tenon withdrawal values so that their true vertical positions, which depend on the correctness of the withdrawal values, could differ from those shown. Nonetheless, the slopes of the curves for the larger stretcher widths do not differ greatly from those for

Table 2. — Regression analyses of data for 0.5-, 0.625-, 0.75-, 0.875-, and 1.0-inch-diameter tenons.<sup>a</sup>

Range of member widths (in)	Regression coefficients		Correlation coefficients
	a	b	$r^2$
1	1.082	1.0	99.99
1	1.089	0.952	100.00
1.25	0.982	1.396	100.0
1.5	0.931	1.580	100.0
1.75	0.901	1.805	100.0
2.0	0.907	1.858	100.0
1 to 2	0.934	1.656	97.44

<sup>a</sup>Regression expression:  $F_s = a \times \frac{2w}{D^b} \times F_{NS}$

the curves fitted to the test data. Thus, it appears that the relationship itself is valid for tenons with wide shoulders but is dependent on valid estimates of tenon withdrawal capacities.

### Bending moment capacity of tenons without shoulders

Presumably, the bending moment capacities of the tenons themselves may be estimated by means of the following form of the flexure formula:

$$F_{NS} = 1.18 \times (\pi \times D^3/32) \times s_4$$

where  $s_4$  = modulus of rupture (MOR) of the wood of which the tenon is constructed (psi); 1.18 = form factor for round beams (Wangaard 1950). It is interesting to note that when an expression of the form  $F_{NS} = a \times D^b$  was fitted to the results for tenons without shoulders, a power coefficient of 2.8 was obtained compared to the classical value of 3 used in the flexure formula above.

The MC of the yellow-poplar wood was 10.5 percent so that the MOR of the wood (FPL 1999) amounted to 10,706 psi. The corresponding calculated bending strengths of the 0.5-, 0.625-, 0.75-, 0.875- and 1-inch diameter tenons amount to 155, 303, 523, 831, and 1,240 in-lb, respectively. The overall ratio of the corresponding test values divided by these values amounts to 1.02. This result tends to indicate that the form factor of 1.18 may be used in estimating the bending moment capacity of round tenons (Newlin and Trayer 1924, Wolfe et al. 2001).

### Conclusions

Results of the tests indicate that useful estimates of the contribution of shoulders to the bending moment capacity of

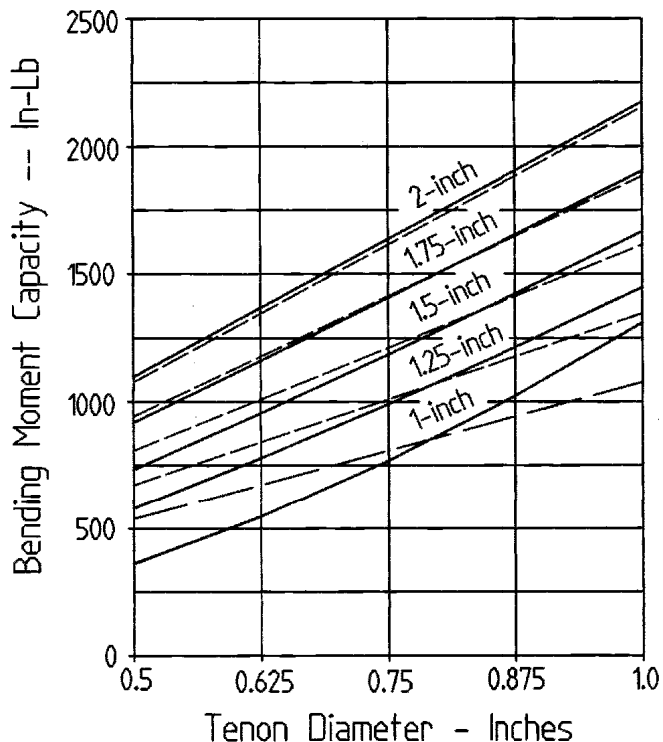

Figure 6. — Tenon withdrawal  $\times$  internal moment arm values shown as dashed lines; regression curves of test results are shown as solid lines.

round mortise and tenon joints may be obtained by means of the expression:

$$F_S = 0.934 \times \frac{2w}{D^{1.66}} \times F_{NS}$$

where  $F_S$  and  $F_{NS}$  = bending moment capacities of joints with and without shoulders, respectively (in-lb);  $w$  = distance from the longitudinal axis of the tenon to the lower edge of the stretcher (in);  $D$  = diameter of the tenon (in).

Results also show that the bending moment capacity of round mortise and tenon joints with shoulders may be estimated by means of the expression:

$$F_S = 0.894 \times w \times T$$

where  $T$  = withdrawal strength of the tenon loaded in tension (lb). Although this expression yields close estimates, the accuracy of the estimates depends upon knowledge of the quality of the adhesive bonds between the walls of the tenon and mortise. Furthermore, this expression is best-suited for joints with small tenons and large shoulders.

Simple working relationships between shifts in the neutral axis, which result from the use of shoulders, and bending moment capacity, were not found. Close fits can be obtained through the use of somewhat complex relationships, but these were not judged useful for practical design purposes.

On average, results of the tests tended to indicate that the bending moment capacity of tenons without shoulders may be estimated by means of the following form of the flexure formula:

$$F_{NS} = 1.18 \times (\pi \times D^3/32) \times s_4$$

where the constant, 1.18, is a form factor used with round beams. This relationship did not hold uniformly for all tenon diameters, however. Hence, questions remain whether the form factor used for round beams can be used with round tenons in mortise and tenon joints.

#### Literature cited

Eckelman, C.A. 1969. Engineering concepts of single-pin dowel joint design. *Forest Prod. J.* 19(12):52-60.

\_\_\_\_\_. 1971. Bending strength and moment rotation characteristics of two-pin moment-resisting dowel joints. *Forest Prod. J.* 21(3): 35-39.

Newlin, J.A. and G.W. Trayer. 1924. The influence of the form of a wooden beam on its stiffness and strength, II. Form factors of beams subjected to transverse loading only. Tech. Rept. 181, Reprinted. U.S. National Advisory Committee for Aeronautics Ann. Rept. 9. pp. 375-393.

USDA Forest Service, Forest Products Laboratory (FPL). 1999. *Wood Handbook: Wood as an Engineering Material.* Forest Prod. Soc., Madison, WI.

Wangaard, F.F. 1950. *The Mechanical Properties of Wood.* John Wiley and Sons, New York. 377 pp.

Wolfe, R.W., J. Bodig, and P.K. Lebow. 2001. Derivation of nominal strength for wood utility poles. Gen. Tech. Rept. FPL-GTR-128. USDA Forest Serv., Forest Prod. Lab., Madison, WI. 11 pp.